

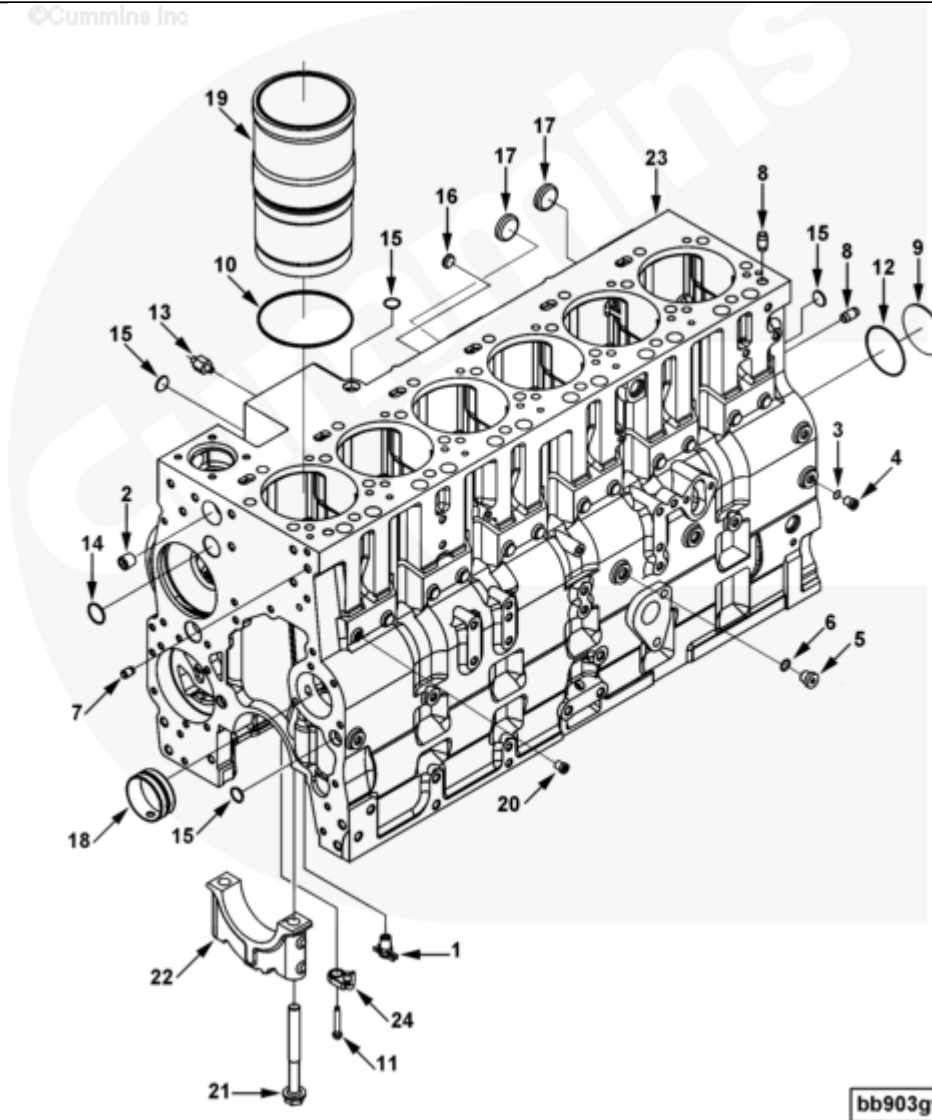

Parts Catalog - Option Detail

Electronic Parts Catalog - Option Detail				
Option	Group	Graphic	Film Card	Date
BB9080-07	01.01	bb903gw	Z	07-OCT-04
Engines	6C8.3, C GAS PLUS CM556, G8.3, G8.3 CM558, GTA8.3 CM558, ISC CM2150, ISC CM554, ISC CM850, ISC8.3 CM2250, ISC8.3 G CM2180 C101, ISL CM2150, ISL CM554, ISL CM850, ISL G CM2180, ISL8.9 CM2150 L110, ISL8.9 CM2880 L112, ISL9 CM2150 SN, ISL9 CM2250, ISL9 CM2350 L101, ISL9 CM2350 L111, ISLE4 CM850, L GAS PLUS CM556, L8.9, L8.9 L121, L8.9G CMOH2.0 L125B, L9 CM2350 L116B, L9 CM2350 L119B, L9 CM2350 L120C, L9 CM2350 L123B, L9.3 L105, L9.5 L117, L9N CM2380 L124B, QSC8.3 CM2250, QSC8.3 CM2880 C102, QSC8.3 CM554, QSC8.3 CM850(CM2850), QSL9 CM2250, QSL9 CM2250 L115, QSL9 CM2350 L102, QSL9 CM2350 L107, QSL9 CM2350 L118, QSL9 CM2350 L122, QSL9 CM554, QSL9 CM850(CM2850), QSL9 G CM558, QSL9 M CM2250 L106, QSL9.3 CM2880 L113			



bb903gw

[SMALL](#) | [MEDIUM](#) | [LARGE](#)

Cart	Ref No	Part Number	Part Description	Required	Remarks
------	--------	-------------	------------------	----------	---------

[View My Cart](#)

		BB9080-07	Cylinder Block		MR - BLOCK, CYLINDER...(More)
					Engine Family: C
					Design Phase: Pegasus Beta
					Piston Cooling Nozzles:
					Targeted
					Tappets: Roller
					Main Bearing Cap Material:
					41,020
					Main Bearing Cap Material
					(lb): 1700
					Flywheel Housing to Block
					Mounting: 12 x M12 x 1.75
					Oil Pan to Block Mounting:
					24 x M8 x 1.25
					Block/Oil Pan Mounting Hole
					Spacing: Equal
					Block/Oil Pan Mounting Hole
					Pitch (mm): 78.5
					Block Flange: 282mm x
					773.5mm
					(Width/Length, Hole to Hole)
					Grounding Stud Location:
					- Fuel Pump Side (Hole #326)
					- Exhaust Side (Hole #442)
<input type="checkbox"/>	1	S 923 E	Draincock	1	
<input type="checkbox"/>	2	3008468	Pipe Plug	1	1/2 NPT.
<input type="checkbox"/>		3678921	Threaded Plug	1	M14 X 1.5 X 16

<input type="checkbox"/>	3	3678912	O-Ring Seal	1	M14
	4	3678922	Threaded Plug	1	M14 X 1.5 X 16
<input type="checkbox"/>		3678923	Threaded Plug	6	M10 X 1.00 X 13.5
<input type="checkbox"/>	5	3678924	Threaded Plug	1	M10 X 1.00 X 13.5
<input type="checkbox"/>	6	3678925	O-Ring Seal	1	M10.
<input type="checkbox"/>	7	3900257	Pin Dowel	2	
<input type="checkbox"/>	8	3901846	Pin Dowel	4	
<input type="checkbox"/>	9	3901969	Expansion Plug	1	
<input type="checkbox"/>	11	3909025	Hexagon Flange Head Cap Screw	6	M8 x 1.25 x 55
<input type="checkbox"/>	12	3926048	O-Ring Seal	1	
<input type="checkbox"/>	13	3966286	Studded Hexagon Cap Screw	1	
<input type="checkbox"/>		4980052	Cylinder Liner	6	
<input type="checkbox"/>		3800328	Liner Kit	6	
<input type="checkbox"/>	10	3907177	Rectangular Ring Seal	1	
<input type="checkbox"/>	19	3948095	Cylinder Liner	1	
<input type="checkbox"/>		3971391	Cylinder Block	1	Sold In Higher Level Assy/Kit
<input type="checkbox"/>	14	143066	Expansion Plug	3	
<input type="checkbox"/>	15	3004258	Expansion Plug	4	
<input type="checkbox"/>	16	3900956	Expansion Plug	3	17.73 mm
<input type="checkbox"/>	17	3905401	Expansion Plug	4	
<input type="checkbox"/>	18	3945329	Bushing	7	
<input type="checkbox"/>	20	3966035	Tappet Guide	12	
<input type="checkbox"/>	21	3970810	Hexagon Flange Head Cap Screw	14	M14 x 2.00 x 135
<input type="checkbox"/>	22	3970955	Main Bearing Cap	7	
	23	3971390	Cylinder Block	1	
<input type="checkbox"/>	24	3973123	Piston Cooling Nozzle	6	
<input type="checkbox"/>		3924445	Shim	A/R	0.25mm Oversize (0.010 in.)
<input type="checkbox"/>		3924446	Shim	A/R	0.38mm Oversize (0.015 in.)
<input type="checkbox"/>		3924447	Shim	A/R	0.51mm Oversize (0.020 in.)
<input type="checkbox"/>		3924448	Shim	A/R	0.75mm Oversize (0.030 in.)

<input type="checkbox"/>		3924449	Shim	A/R	1.00mm Oversize (0.040 in.)
--------------------------	--	-------------------------	------	-----	-----------------------------

© 2019 Cummins Inc., Box 3005, Columbus, IN 47202-3005 U.S.A.
Terms of Use and Disclaimers | Recommended System Requirements
Need Assistance? Please click on the Contact Us button in the top right corner of any page.